

<b>Davicom Semiconductor Inc.</b>		
Title	<b>3 Port Switch + uP Interface Chip</b>	
Size	Document Number	Rev
B	<b>DM9016_EVB_BOARD</b>	1.0
Date:	Wednesday, March 18, 2009	Sheet 1 of 3

# MII Interface

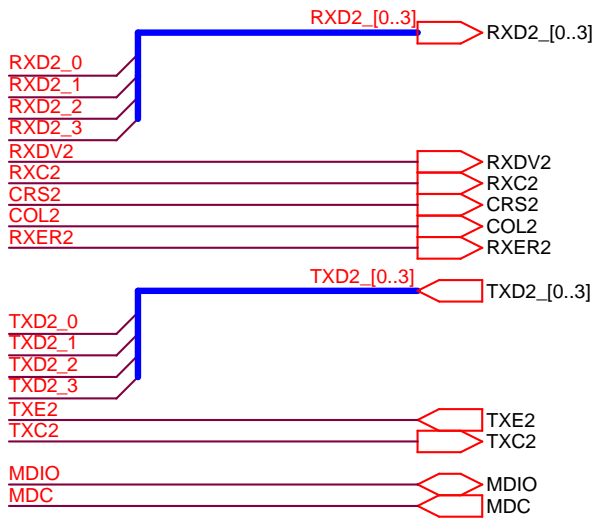

# uP Interface

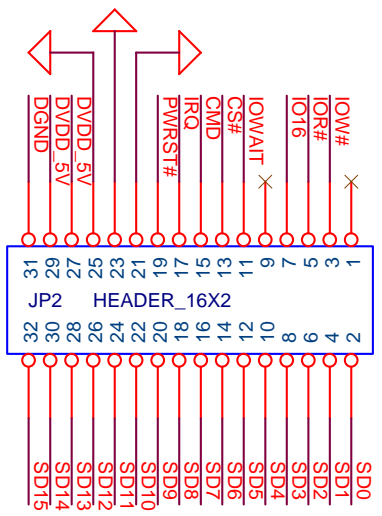
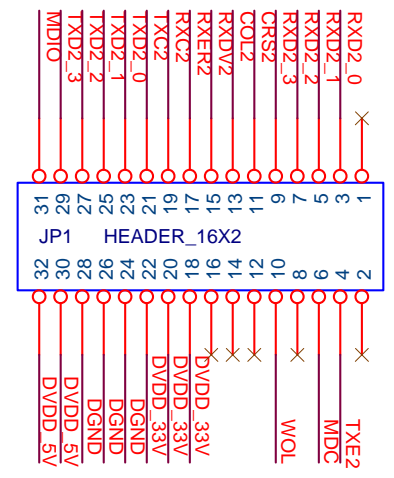
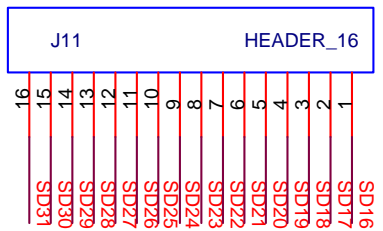
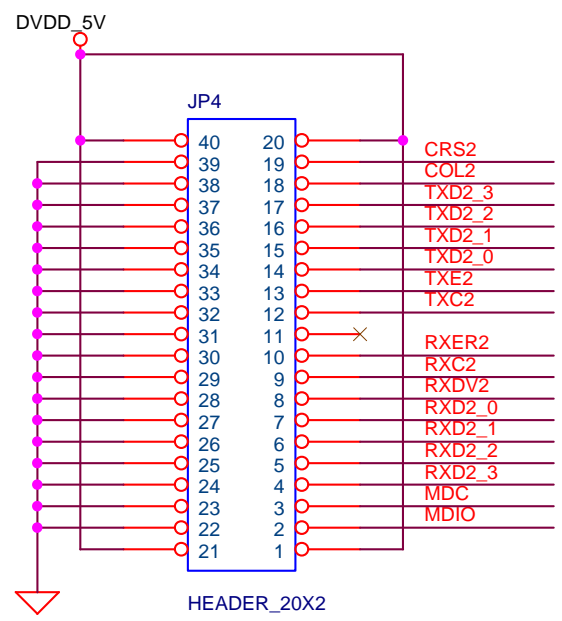
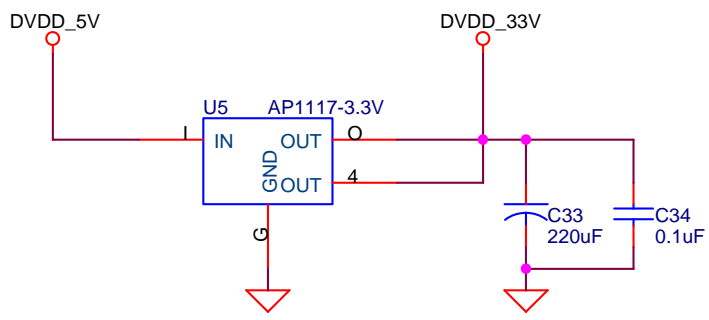
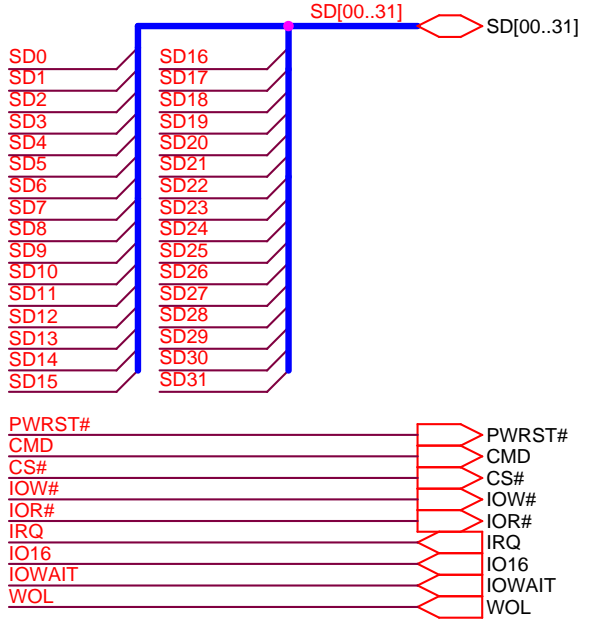

<b>Davicom Semiconductor Inc.</b>		
Title		
3 Port Switch + uP Interface Chip		
Size	Document Number	Rev
A	DM9016_EVB_BOARD	1.0
Date:	Wednesday, March 18, 2009	Sheet 2 of 3

# TP / LED Interface

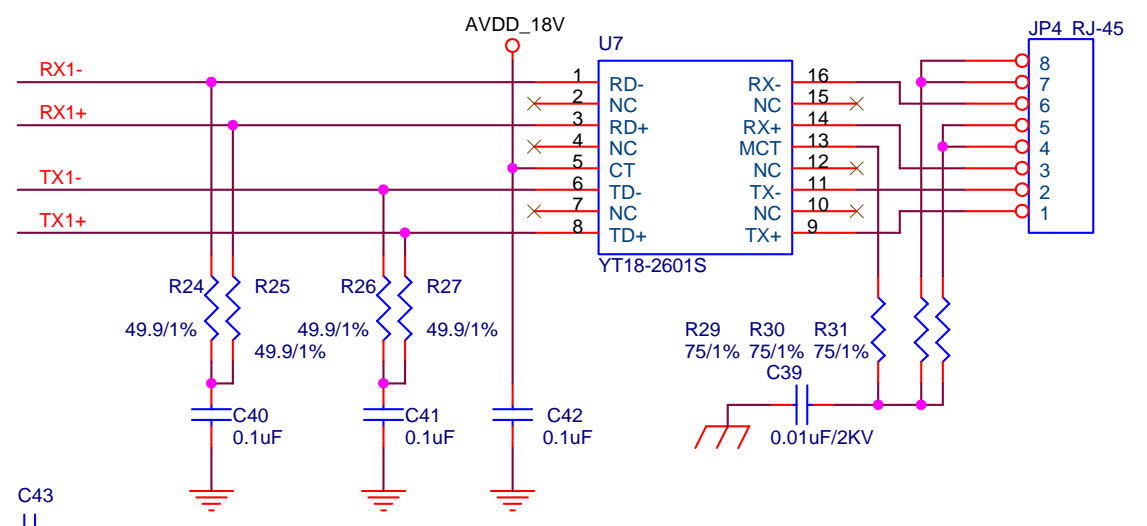
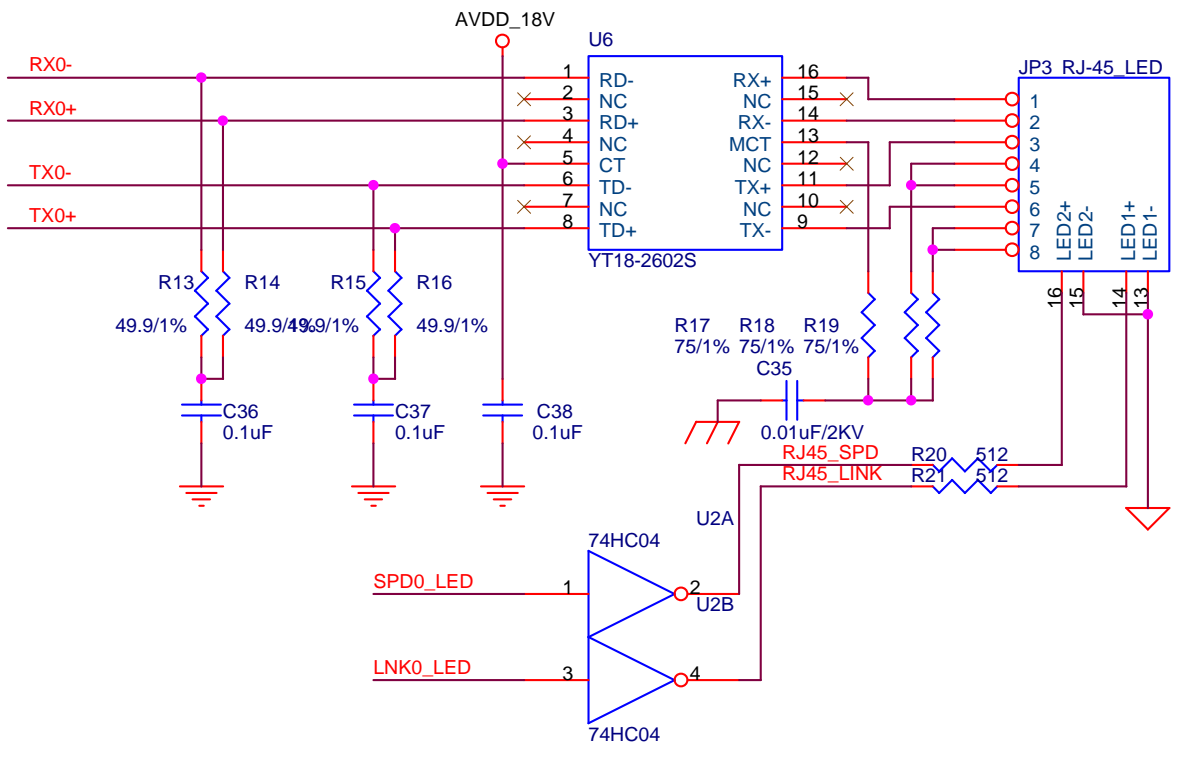
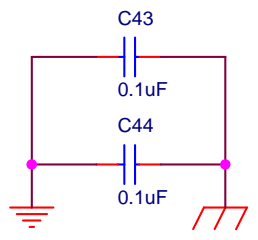
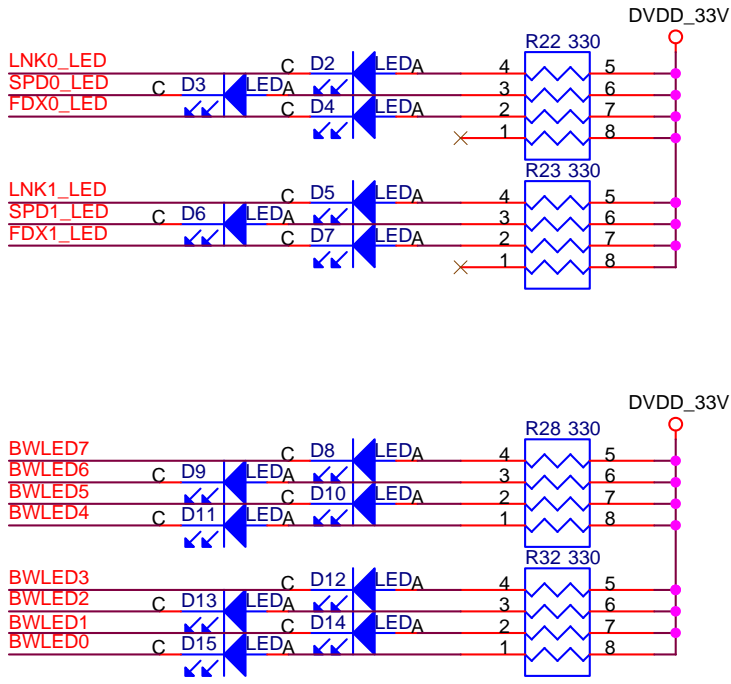
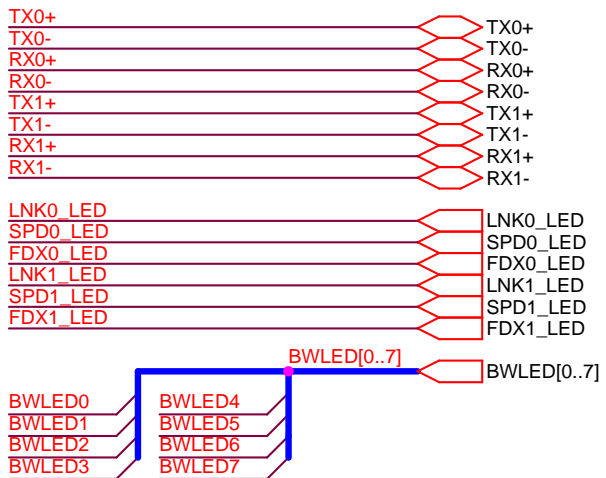

<b>Davicom Semiconductor Inc.</b>		
Title		
3 Port Switch + uP Interface Chip		
Size	Document Number	Rev
A	DM9016_EVB_BOARD	1.0
Date:	Wednesday, March 18, 2009	Sheet 3 of 3