

LAN8740 / LAN8741 MII PHY Customer Evaluation Board

Assy 6695
 PCB Revision A
 Schematic Revision 1.1

Design Details

Board:
 Assy 6695

Chip:
 SMSC LAN8740 / LAN8741

Board Form Factor:
 MII

Assembly:
 32 Lead QFN w/ Exposed GND Pad

Circuit Diagrams utilizing SMSC Products Are Included As A Means Of Illustrating Typical Semiconductor Applications: Consequently Complete Information Sufficient For Construction Purposes Is Not Necessarily Given. The Information Has Been Carefully Checked And Is Believed To Be Entirely Reliable. However, No Responsibility Is Assumed For Inaccuracies. Furthermore, Such Information Does Not Convey To The Purchaser Of The Semiconductor Devices Described Any License Under The Patent Rights Of SMSC Or Others. SMSC Reserves The Right To Make Changes At Any Time In Order To Improve Design And Supply The Best Product Possible.

Revision History

Rev 1.0:

Initial release, Rev C

Rev 1.1:

Page 2: Added R40 & R41 in rework
 R20 changed to 0 Ohm
 C13 and C14 changed to 39pF

BLOCK DIAGRAM

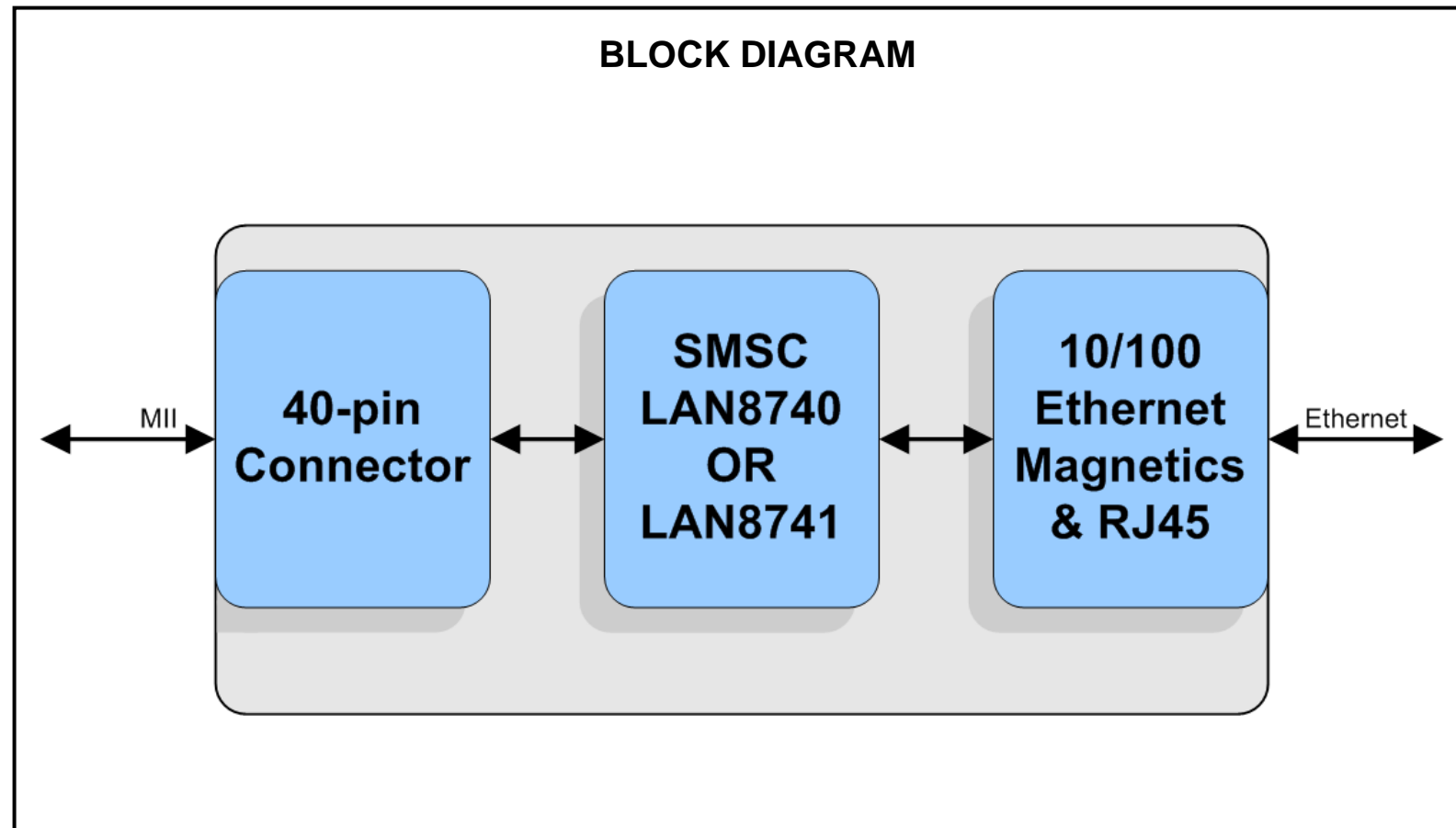

ITEM	Page(s)
Title Page	1
LAN8740 / LAN8741 MII PHY Customer Evaluation Board	

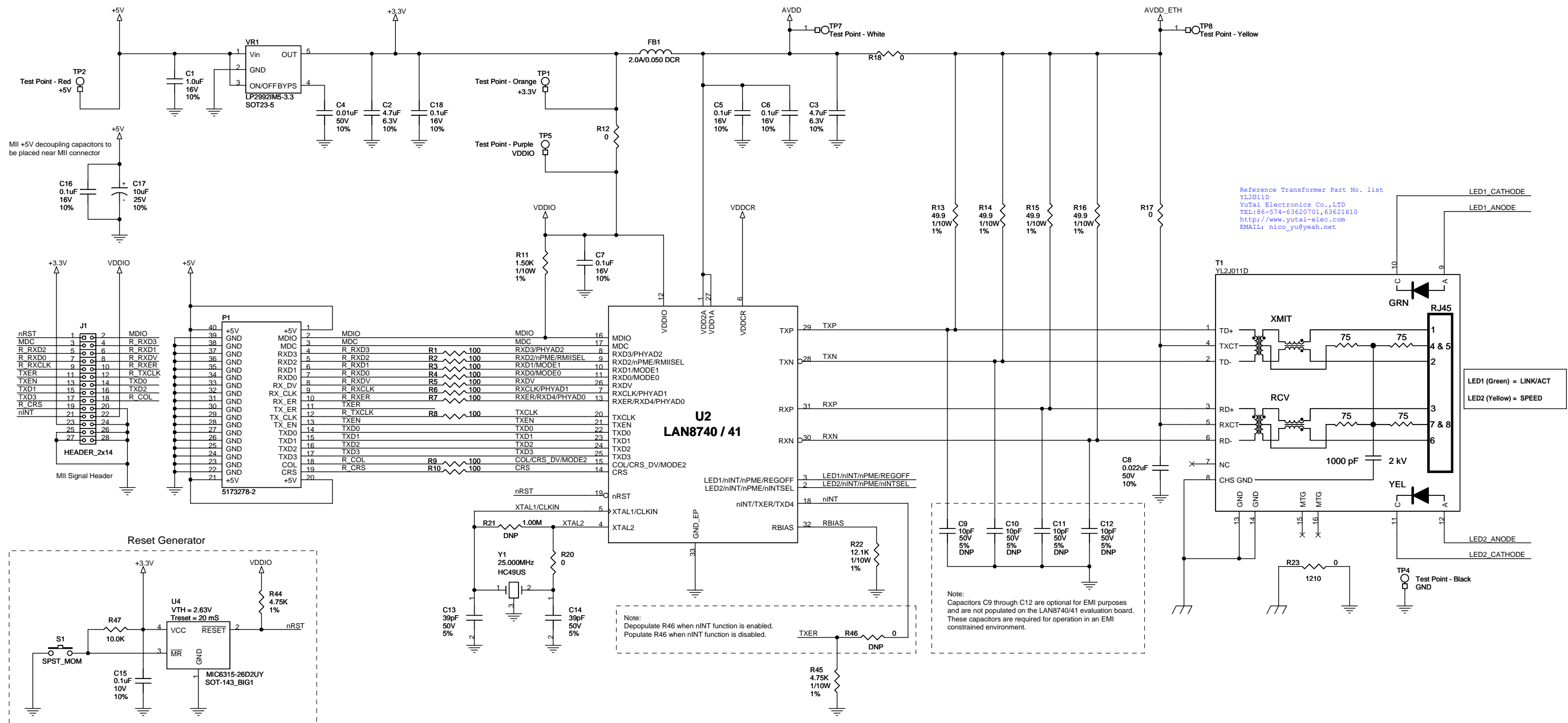

Reference Transformer Part No. list
 YL2011D
 Yutai Electronics Co.,LTD
 TEL:86-574-63620701,63621610
 http://www.yutai-elec.com
 EMAIL: nico_yu@yeah.net

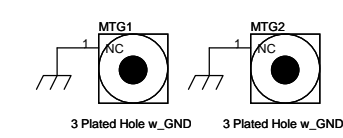
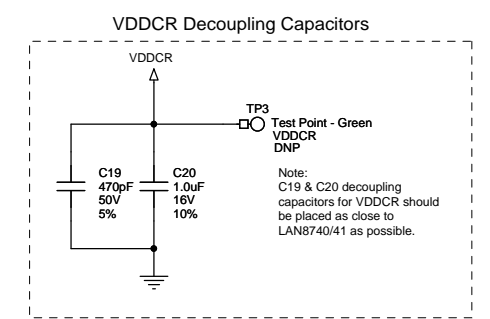
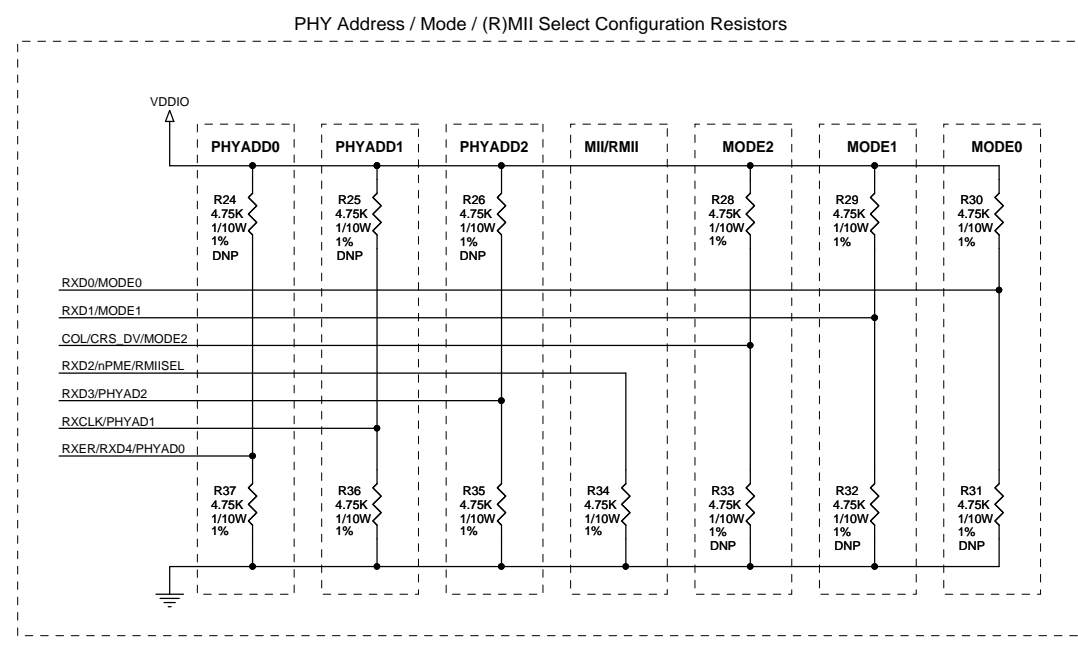
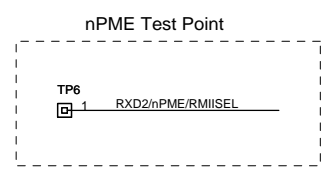
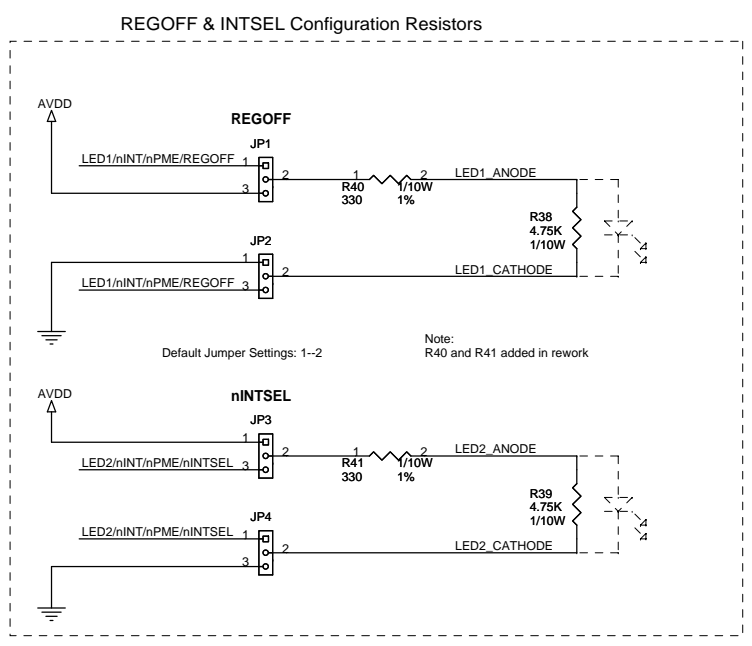
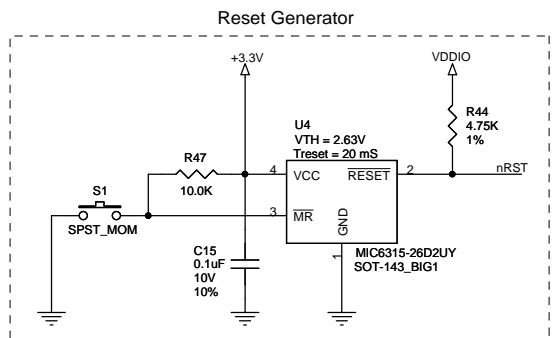

SMSC SUCCESS BY DESIGN				
Title LAN8740 / LAN8741 MII PHY Customer Evaluation Board				
Size	Engineer	Assembly No.	PCB Rev	Schematic Rev
	J.M.	6695	A	1.1
Date:	Wednesday, August 29, 2012			Sheet 2 of 2