

LAN9303M Reference Design

Schematic Revision 1.4

Circuit Diagrams utilizing SMSC Products Are Included As A Means Of Illustrating Typical Semiconductor Applications: Consequently Complete Information Sufficient For Construction Purposes Is Not Necessarily Given. The Information Has Been Carefully Checked And Is Believed To Be Entirely Reliable. However, No Responsibility Is Assumed For Inaccuracies. Furthermore, Such Information Does Not Convey To The Purchaser Of The Semiconductor Devices Described Any License Under The Patent Rights Of SMSC Or Others. SMSC Reserves The Right To Make Changes At Any Time In Order To Improve Design And Supply The Best Product Possible.

ITEM	Page (s)
Title Page	1
LAN9303M	2
LAN9303M Ethernet Ports	3

Revision History

Rev 1.0 to 1.2:

All Pages: Update to page formatting.

Rev 1.2 to 1.3:

Page 3: Changed Ethernet magnetics module center-tap resistor values (R28, R37) from 49.9 Ohms to 10.0 Ohms.

Rev 1.3 to 1.4:

Page 2: Added note stating I2C pull-ups are required when operating without an EEPROM.

			
Title			
Size	Engineer	Assembly No.	Rev
C	R. Walsh	LAN9303M	1.4
Date: Friday, June 11, 2010		Sheet 1 of 3	

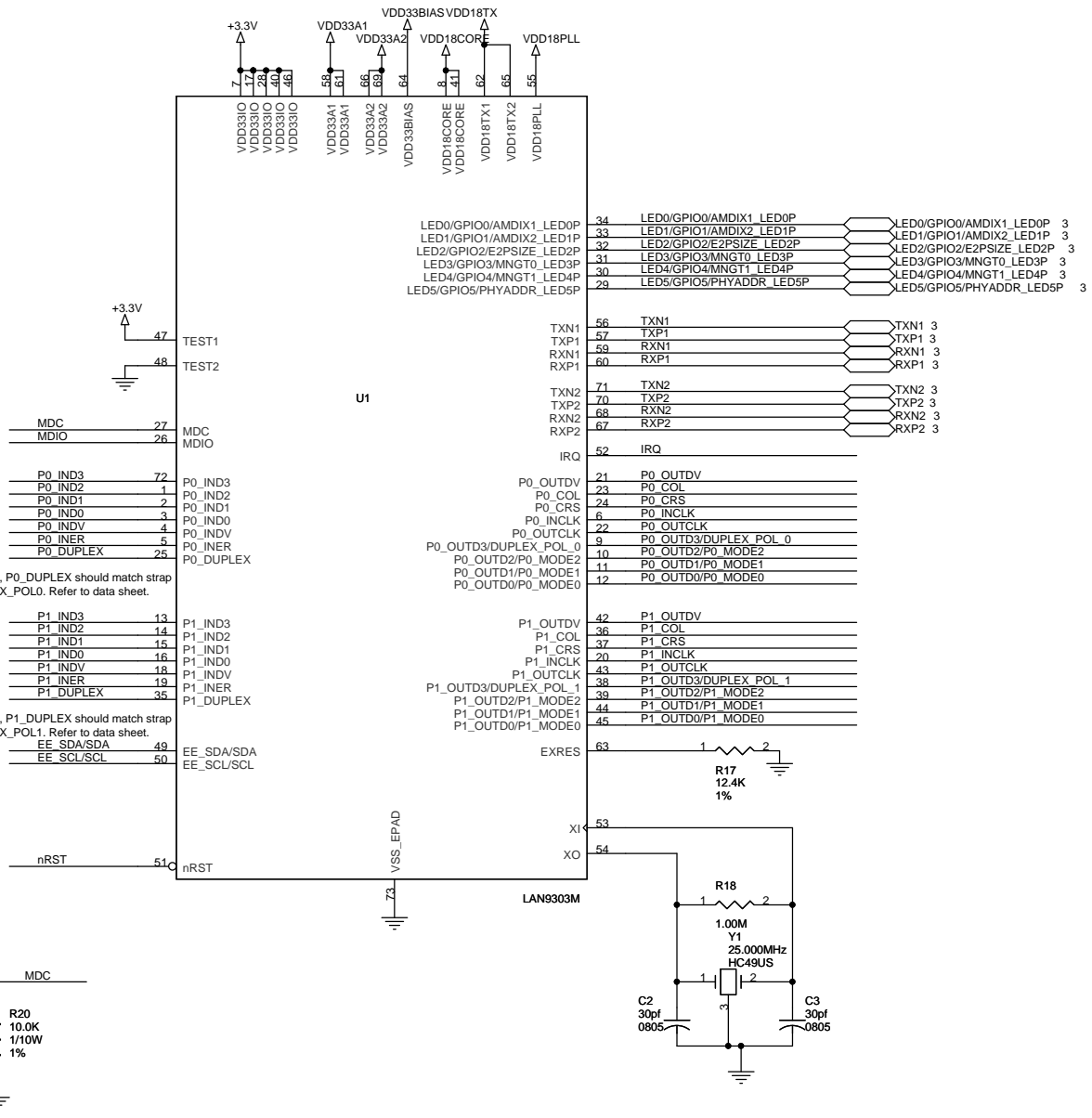

To enable full duplex, P0_DUPLEX should match strap value for P0_DUPLEX_POL0. Refer to data sheet.

To enable full duplex, P1_DUPLEX should match strap value for P1_DUPLEX_POL1. Refer to data sheet.

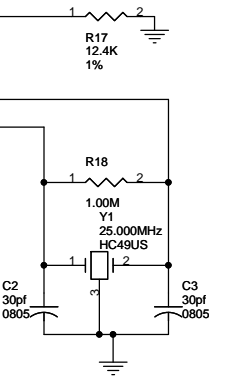
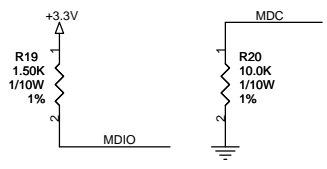

Power Supply Filtering LAN9303M

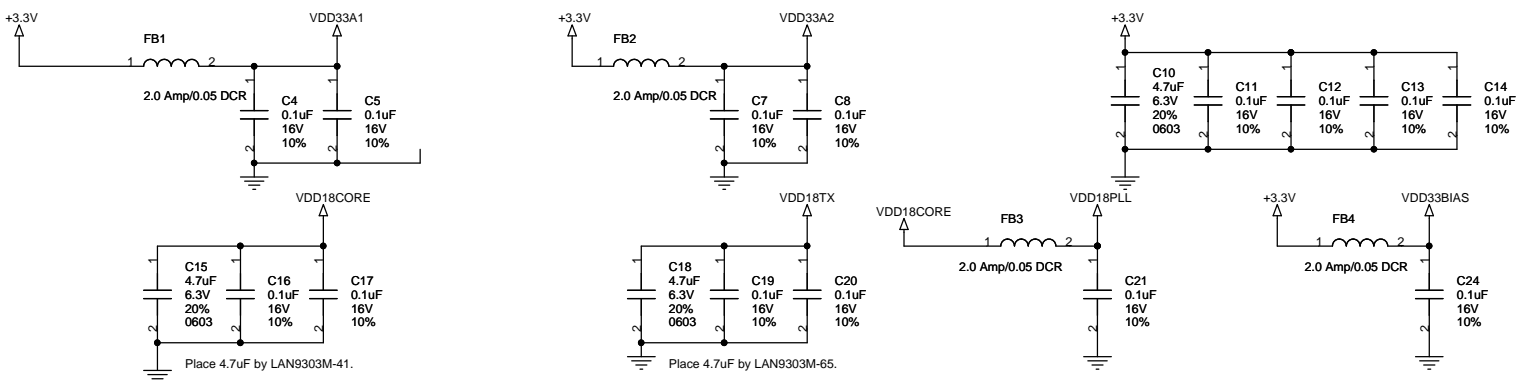

Optional Mode Select.

Place R2, R6, R10, R14 near the PO_OUTD0-3 signals. They serve to isolate the OUT DATA from the trace stub that runs to the strap pull-ups and Switch. Same for R4, R8, R12 and R16.

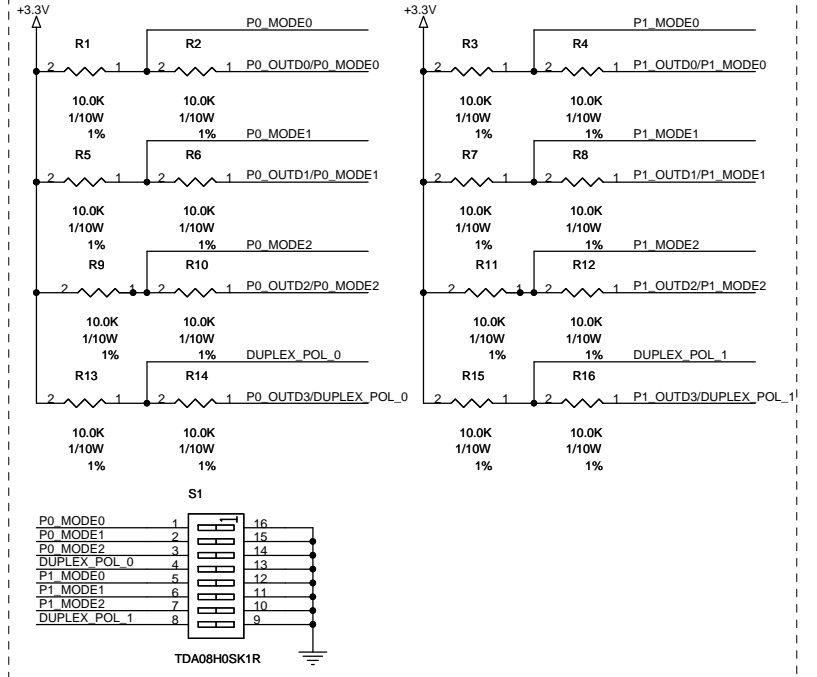

Optional I2C Serial EEPROM

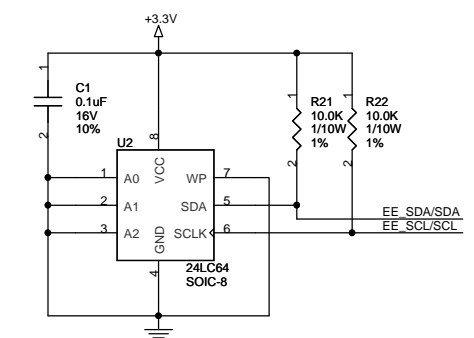

IMPORTANT NOTE:
Pull-ups are required on the EE_SDA/SDA and EE_SCL/SCL pins whether an EEPROM is used or not used.

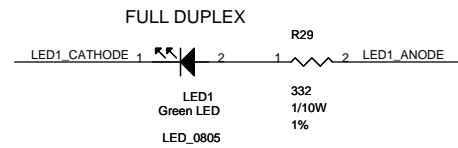
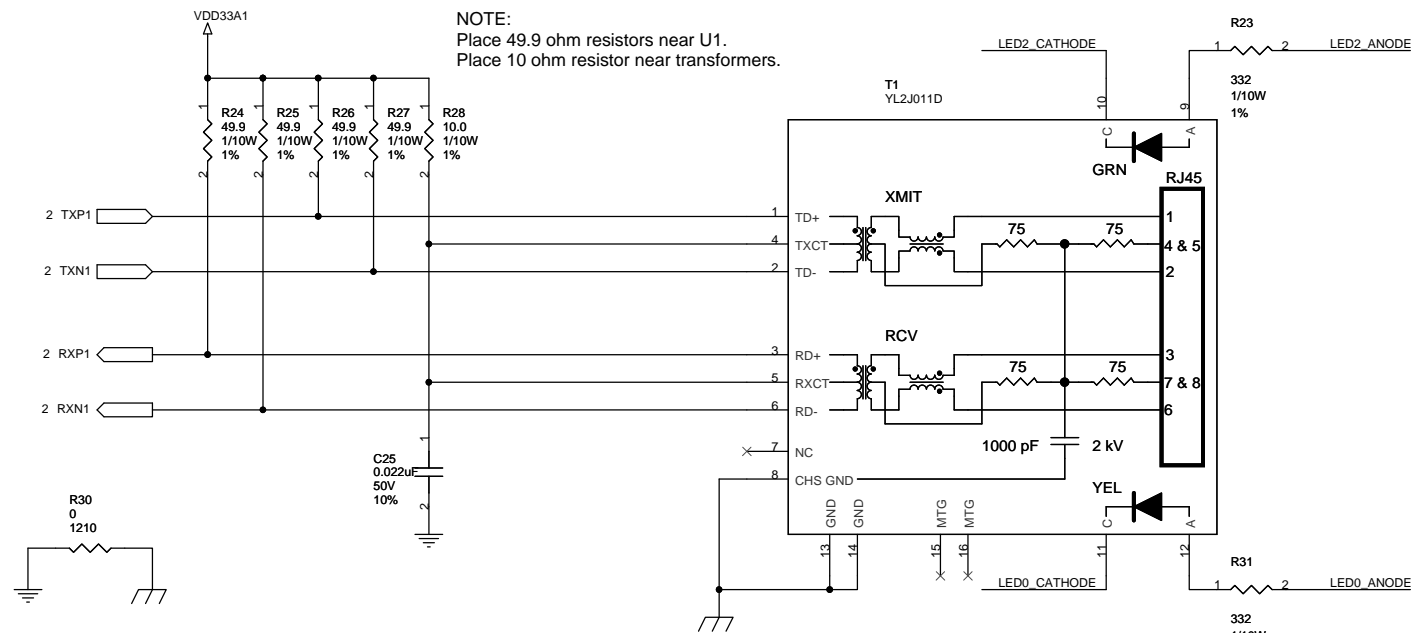

IMPORTANT NOTE:
Populate these capacitors near magnetics in an EMI Constrained environment.

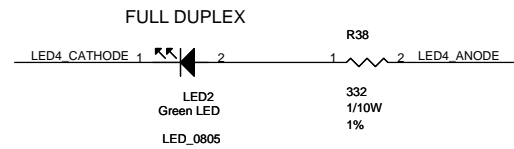
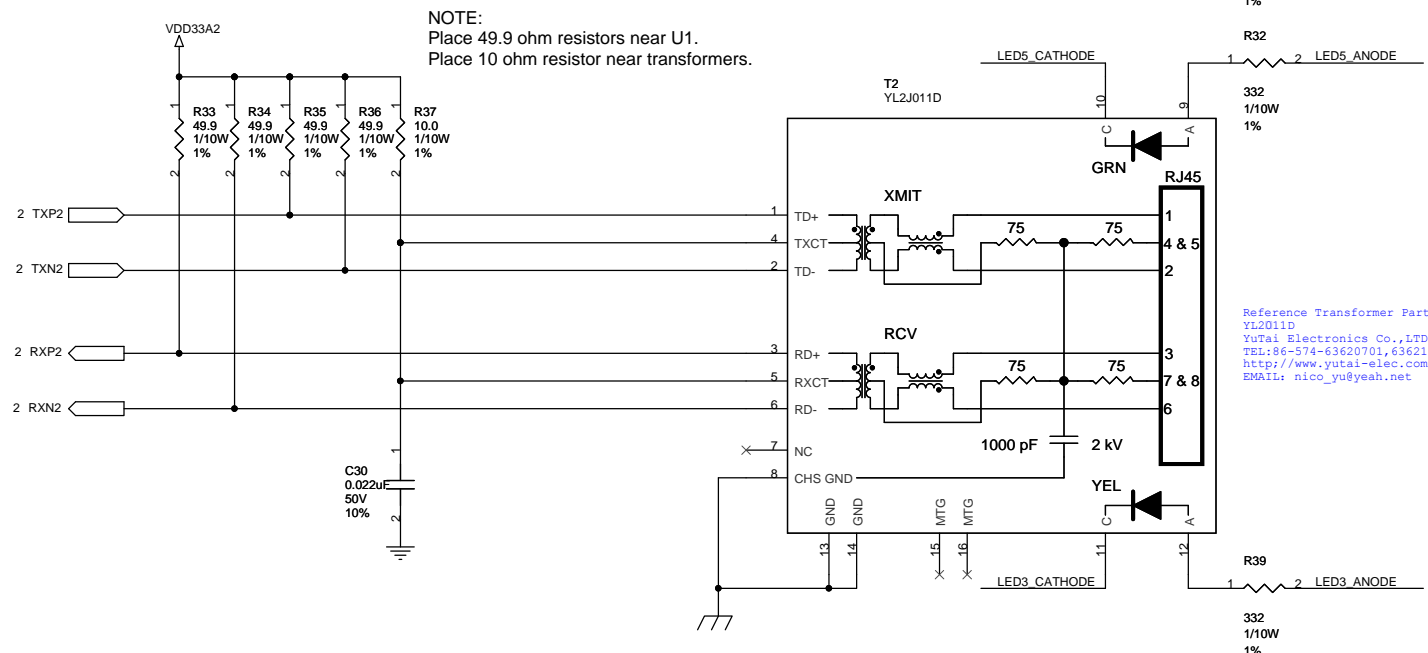
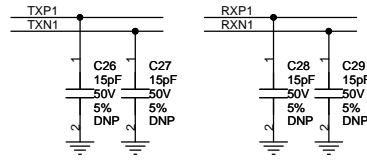

IMPORTANT NOTE:
Populate these capacitors near magnetics in an EMI Constrained environment.

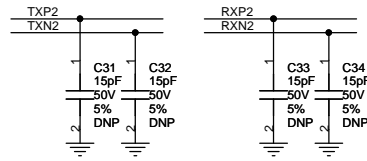

Reference Transformer Part No. list
YL2J011D
YuTai Electronics Co.,LTD
TEL:86-574-63620701,63621610
http://www.yutai-elec.com
EMAIL: nice_yu@yeah.net

Optional LED Strap Circuitry.

Vertically aligned jumpers, i.e. JP1 and JP7, should be set to the same setting. For example, Setting JP7 1-2 and JP13 1-2 selects AUTOMDIX1 enabled.

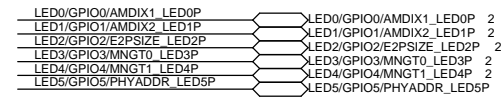
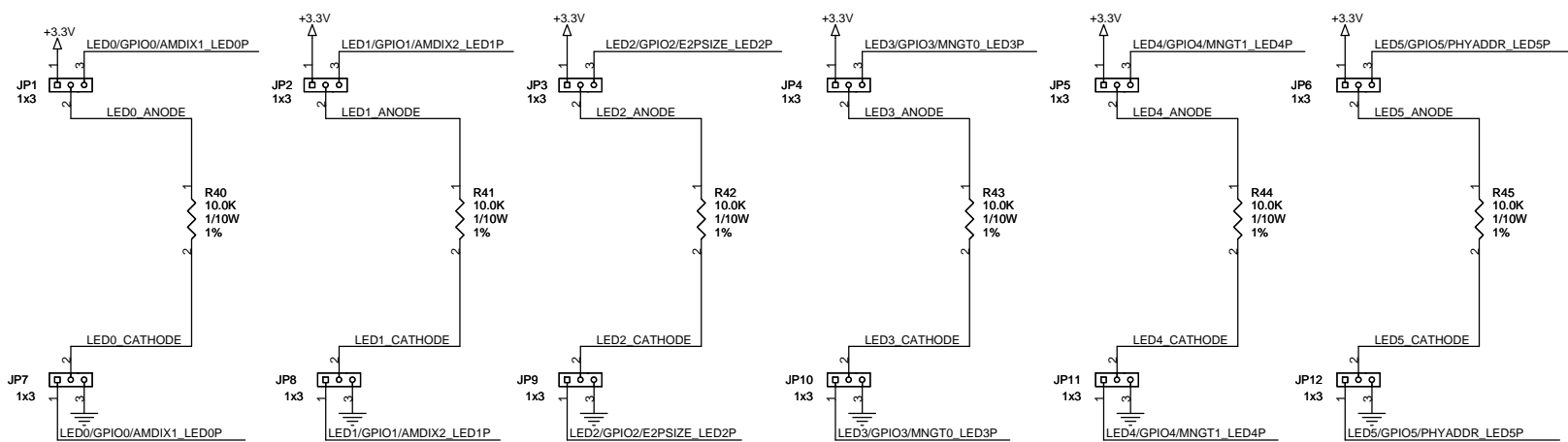

Title			
LAN9303M Ethernet Ports			
Size	Engineer	Assembly No.	Rev
C	R. Walsh	LAN9303M	1.4
Date:	Thursday, June 10, 2010	Sheet	3 of 3