

DATE	REVISION NUMBER	INITIALS	DESCRIPTION
01/26/2011	AR8035 Reference Design V1.0	Izhou	INITIAL REVISION
03/14/2011	AR8035 Reference Design V1.1	Nyin	ADD 4.7uH/500mA description

AR8035 Reference Design V1.0
AR8035: GbE PHY Transceiver

**ATHEROS CONFIDENTIAL
PRELIMINARY**

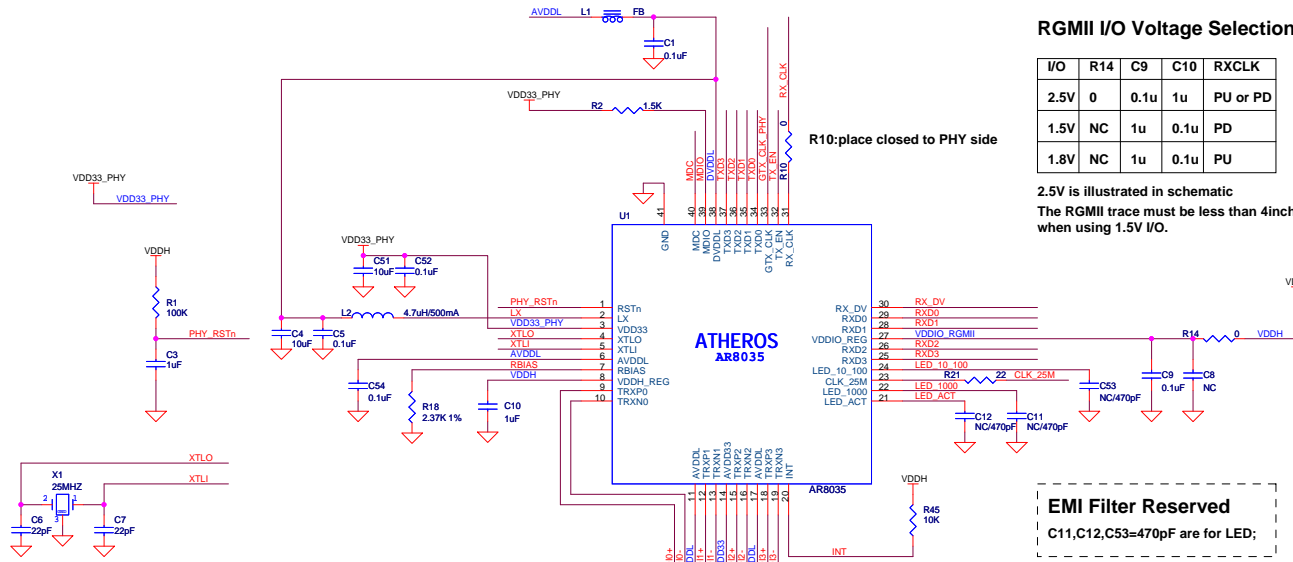

RGMII I/O Voltage Selection

I/O	R14	C9	C10	RXCLK
2.5V	0	0.1u	1u	PU or PD
1.5V	NC	1u	0.1u	PD
1.8V	NC	1u	0.1u	PU

2.5V is illustrated in schematic
The RGMII trace must be less than 4inch when using 1.5V I/O.

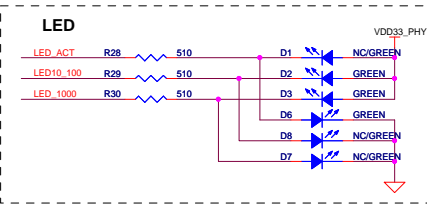
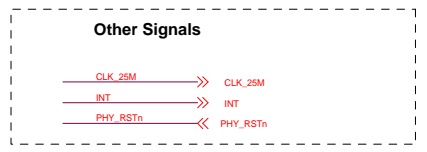
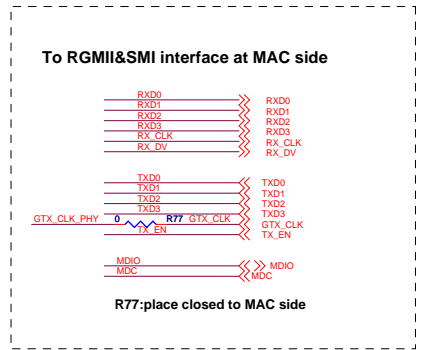

Power-on Strapping Pins

